

O-CIH-XXXXXXXX-X Very Low Phase Noise Rev. S
Precision SC-cut HF OCXO in 1"x1" Through Hole Package

Product Data Sheet

Features

- SC-cut crystal
- Ultra Low Phase Noise
- Sine Wave +17 dBm output
- Compact package

Applications

- Radar
- Instrumentation and Test Equipment
- Synthesizers
- References

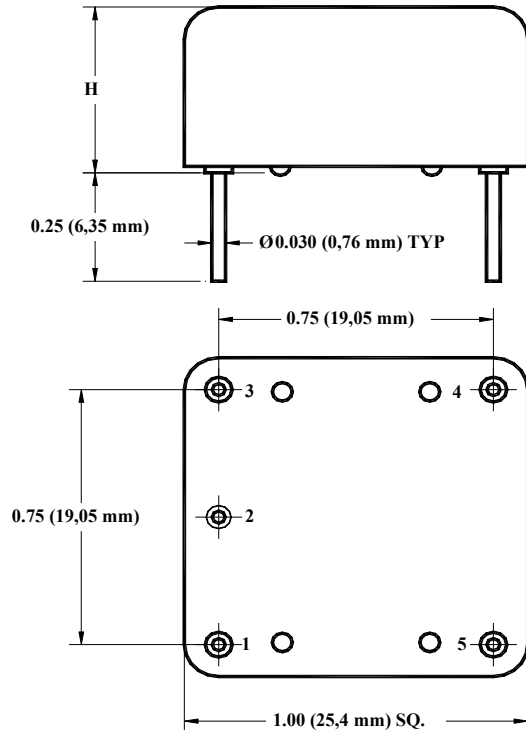

Stand-off positions may vary.

H Code	Height, inches, Typ
4	0.4 (10.2 mm)
5	0.5 (12.7 mm)

Code 5 is standard unless code 4 is requested.

Parameter	Symb	Condition	Min	Typ	Max	Unit	Note															
Absolute Maximum Ratings																						
Input Break Down Voltage	V _{cc}		-0.5		13.0	V	V _{cc} option F V _{cc} option 0															
Storage temper.	T _s		-55		85	°C																
Control Voltage	V _c		-1		10	V																
Electrical (1)																						
Frequency	F		80		128	MHz																
Frequency stability	ΔF/F	vs. Temp.		±50		ppb	See table below															
		vs. Supply			2	ppb/5% change																
		Vs. load			2	ppb/5% change																
Aging		per day per first year 10 years		5E-9 5E-7		ppm	After 30 days of continuous operation															
Allan Deviation		.01s to 1s		5E-11																		
SSB Phase Noise	£(Δf)	10 Hz 100 Hz 1 KHz 10 KHz ≥100 KHz				-95 -125 -158 -170 -178	dBc/Hz	Grade "L"														
									10 Hz 100 Hz 1 KHz 10 KHz ≥100 KHz				-100 -130 -160 -172 -178	Grade "P"								
															10 Hz 100 Hz 1 KHz 10 KHz ≥100 KHz				-105 -135 -162 -175 -178	Grade "U", Available with slope option "L"		
																					10 Hz 100 Hz 1 KHz 10 KHz ≥100 KHz	
		All parameters for 100.000 MHz																				
									Retrace		After 30 minutes		±20									
									G-sensitivity		worst direction			±0.5	ppb/G							
									Input Voltage	V _{cc}	12V±5%	11.4	12.0	12.6	V	Option "F"						
											5V±5%	4.75	5.0	5.25	V	Option "0"						
									Power consumption	P	steady state, 25°C		1.2	1.5	W	Still air						
											steady state, -40°C		2.5									
											start-up		3.0	3.5								
									Spectral Purity		Output power	13	17		dBm	Non-supply related						
											Subharmonics		none		dBc							
											Spurious			-80								
											Harmonics		-35	-30								
Load	50 Ohm (Internally AC-coupled)																					
Warm-up time	τ								to 0.1ppm accuracy		3	5	minutes									
Output Waveform	Sine-wave																					
Control voltage	V _c									0		10.0	V	Slope option "L" Slope option "P"								
			0		4.5																	
Pull range		from nominal F		±3.0		ppm																
Modulation Bandwidth	MBW	V _c port input LPF 3dB cut-off freq.	DC		1	KHz	Note 3															
Absolute pull range	APR	Over all conditions	±0.5			ppm																

Deviation slope		Monotonic, posit		0.7 1.3		ppm/V	Slope option "L" Slope option "P"
Linearity			±10%				
Reference Voltage	Vref			N/A 4.5		V	Slope option "L" Slope option "P"
Setability	Vc0	@25°C, Fnom.	4.0 1.75	5.0 2.25	6.0 2.75	V	Slope option "L", no bias Slope option "P"

Note: 1. All parameters, unless otherwise specified, are at nominal conditions, ie: T=25°C, Nominal Vcc & Nominal Load.
3. Older and stock units may have MBW of 150 Hz Max.

Environmental and Mechanical

Operating temp. range	0 to 70°C Standard, Other options – see Chart below **
Mechanical Shock	Per MIL-STD-202, 30G, 11ms
Thermal Shock	Per MIL-STD 883, Method 1011, Condition A
Vibration	Per MIL-STD-202, 5G to 2000 Hz
Operational vibration	Phase noise under vibration to be verified by the customer
Seal	Per MIL-STD 883, Method 1014, Cond A and Cond C
Soldering Conditions	260°C for 10s Max leads only

Electrical Connections

Pin Out	Pin #1- Output ; Pin #2 – GND; Pin #3 – Voltage Control; Pin#4 – Vref or NC; Pin#5 - Vcc
----------------	--

Creating a Part Number

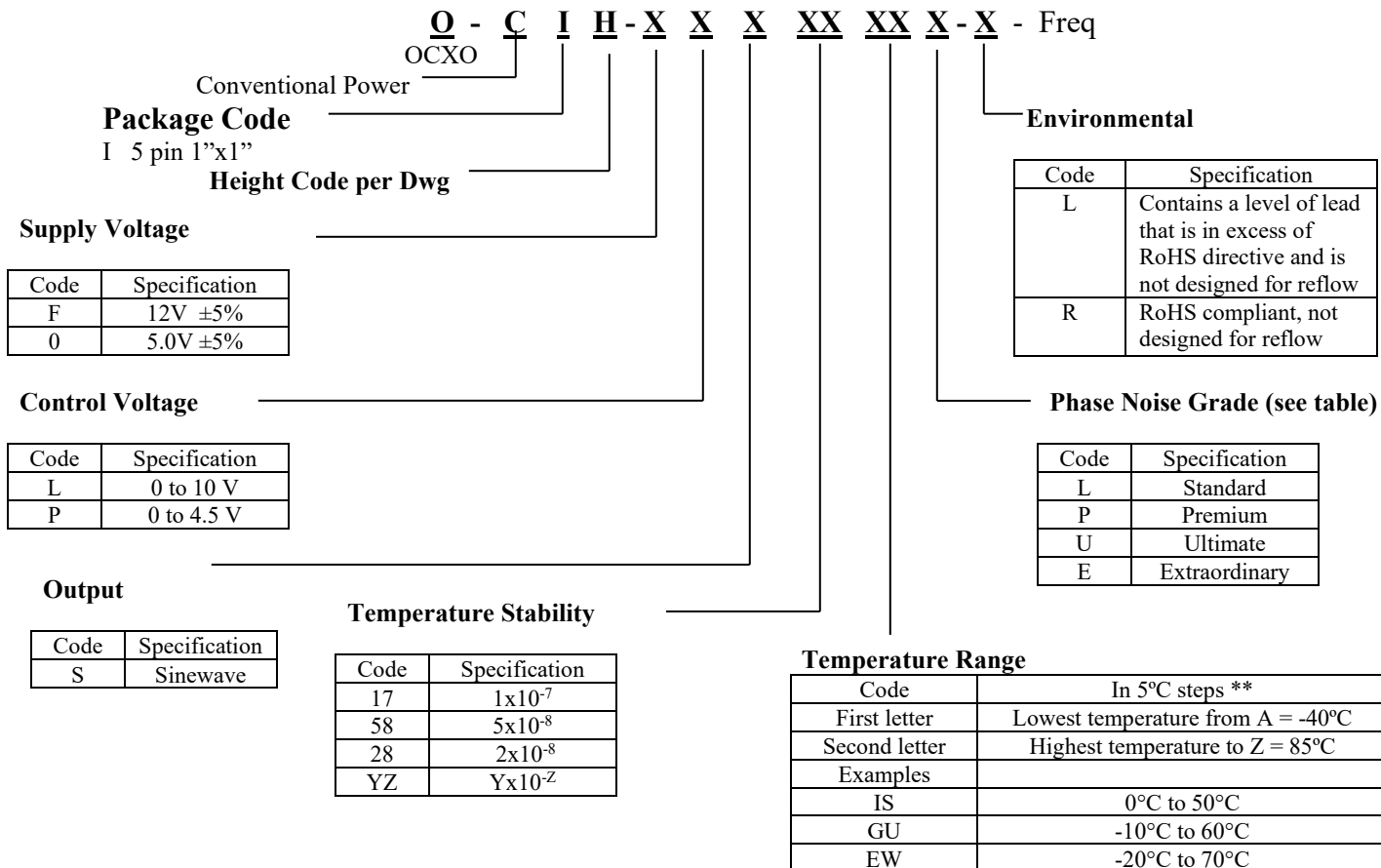

****Temperature Code Table**

Letter	Temp °C	Letter	Temp °C	Letter	Temp °C	Letter	Temp °C	Letter	Temp °C	Letter	Temp °C
A	-40	F	-15	K	10	P	35	U	60	Z	85
B	-35	G	-10	L	15	Q	40	V	65		
C	-30	H	-5	M	20	R	45	W	70		
D	-25	I	0	N	25	S	50	X	75		
E	-20	J	5	O	30	T	55	Y	80		

Note 2 **: The units will be functional down to -55°C with expected deterioration of frequency Stability by up to 2ppm.

Phase Noise Plot:

100 MHz Output Frequency

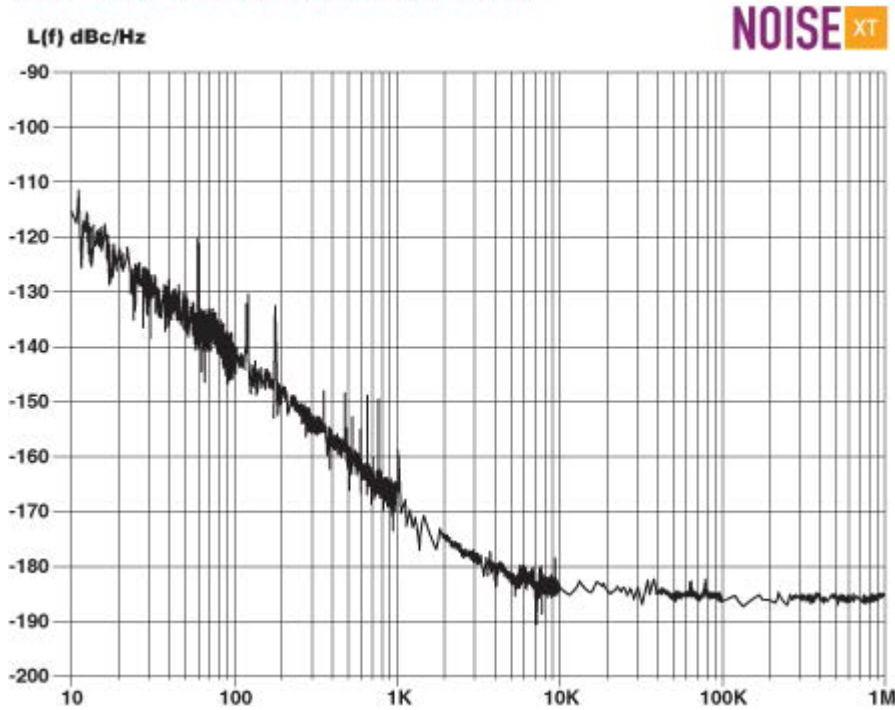

Drawn by:	RB/SS	Date:	07/23/10
Tech Dir:	RB	Date:	07/26/10
Design Eng:	RK	Date:	07/26/10
Eng Mgr:	DTJ	Date:	07/26/10
VP Sales/Mktg:	CU/DK	Date:	07/26/10

REVISION HISTORY

ECO	REV	DESCRIPTION	DRW	DSN ENG	TECH DIR	VP Sales/ Mktg	Date
16258	A	Setability chgd from 4.5, 5.0, 5.5 & 2.0, 2.25, 2.5 To: 4.0, 5.0, 6.0 & 1.75, 2.25, 2.75	BLN	DTJ		DK	03/29/11
16507	B	Added note 1 "All parameters...25°C.."	BLN	DTJ		Na	09/15/11
16571	C	Features chgd from Sine wave +13dBm to +17dBm; Spectral Purity chgd from 10 min & 13 typ to 14 min & 17 typ	BLN	DTJ		CU	10/21/11
16917	D	Added Extreme Phase Noise & various updates	BLN	DTJ		CU	08/07/12
16958	E	Operating temp range add ** & added Note 2	BLN	DTJ		CU	09/12/12
17048 & 17049 17079	F	Phase noise E grade at 100Hz chgd from -135 max to -135 typ Corrected Pin out listing	BLN	DTJ		DK	11/13/12
	G	Chgd prod from O-CI-xxxxxxx-x to O-CIH-xxxxxxx-x; Outline dwg chgd height dim to "H" & added H code chart	BLN	DTJ		CU	12/12/12
17110	H	Mod Bandwidth changed from 150Hz max to DC min, 1KHz max; added note: 3	BLN	DTJ		CU	01/24/13
17161	J	Updated phase noise plot	BLN	DTJ		DK	02/20/13
17659	K	Chgd from Allan Variance to Allan Deviation	BLN	DTJ		Na	04/09/14
17732	L	Changed pull range from ±3.0min to ±3.0typ	BLN	DTJ		CU	06/18/14
18172	M	Chgd from Extreme to Extraordinary	BLN	DTJ		CU	07/09/15
18203	N	Updated Phase Noise Plot	BLN	DTJ		CU	08/04/15
19107	P	Update Frequency (120 to 128MHz), include new applications	SA	DTJ		CU	01/09/18
19645		Update NEL address	DK	DTJ	RB	CU	07/31/19
19808	R	"E" grade change -105 to -108; -135 to -138 and move to the max column.	DK	DTJ	RB	CU	10/23/19
19924	S	CHANGE "E" GRADE PHASE NOISE BACK; 10Hz -105 MAX, 100Hz -135 TYP	DK	DTJ	RB	CY	01/28/20